AUTOMOTIVE ALUMINUM: GROWTH THROUGH LIGHTWEIGHTING



Novelis

KAISER
ALUMINUM



Aleris

 Constellium

RioTinto
Alcan



sapa:

SOUTHERN AUTOMOTIVE CONFERENCE

OCTOBER 19, 2015

ALUMINUM TRANSPORTATION GROUP (ATG)



50 YEARS OF ALUMINUM GROWTH

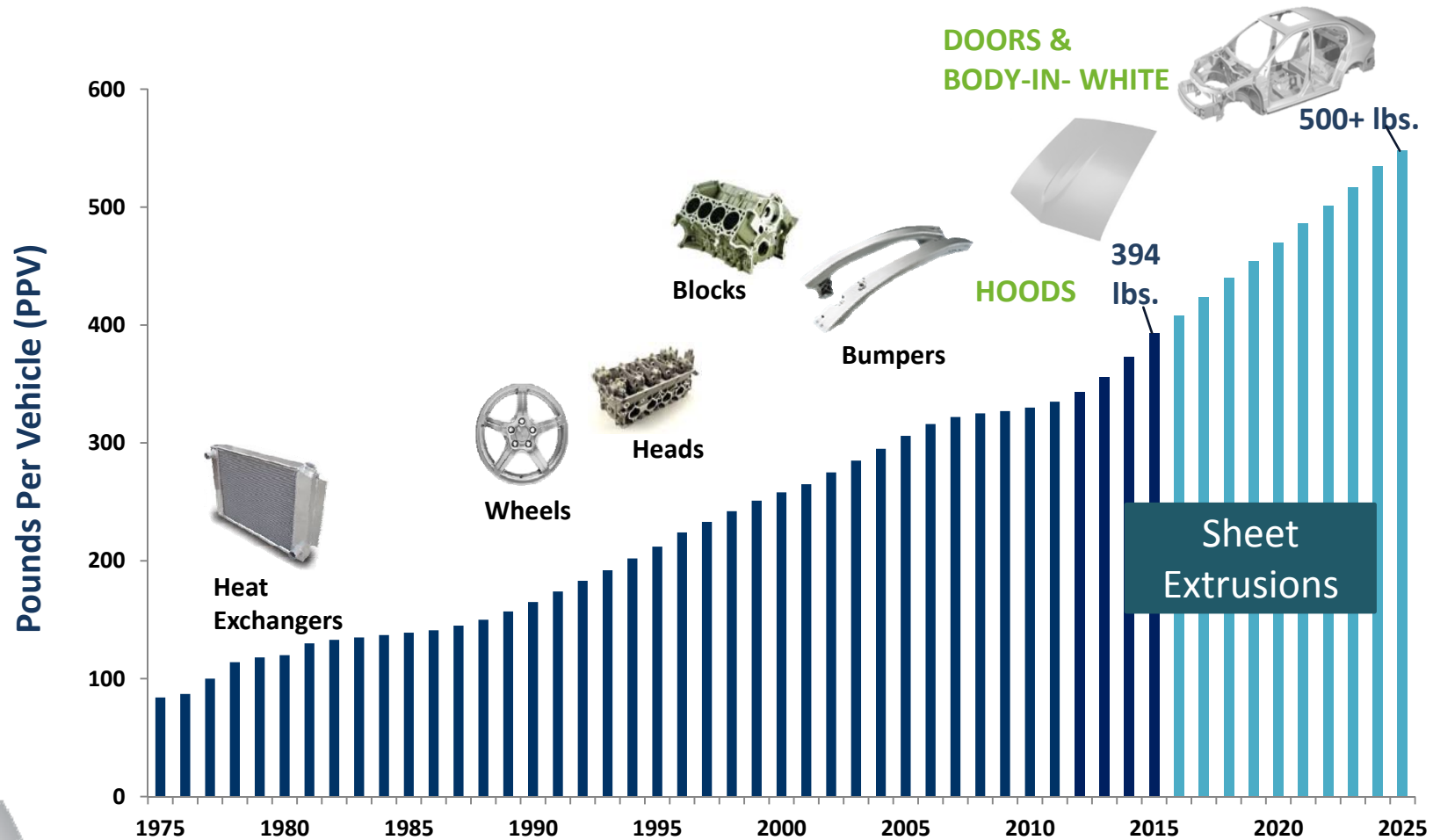

ALUMINUM SHEET CONTENT – CLOSURES

- Aluminum by 2025:
 - Closure Panels: 26%
 - Hoods: 85%
 - Gauge: 1-3 mm

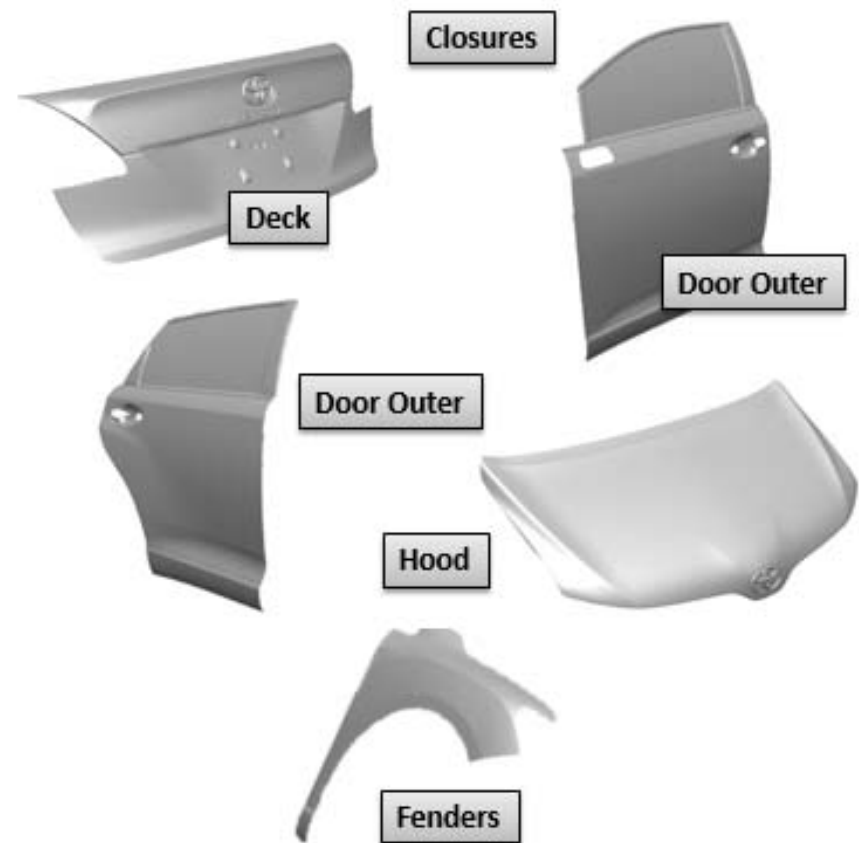
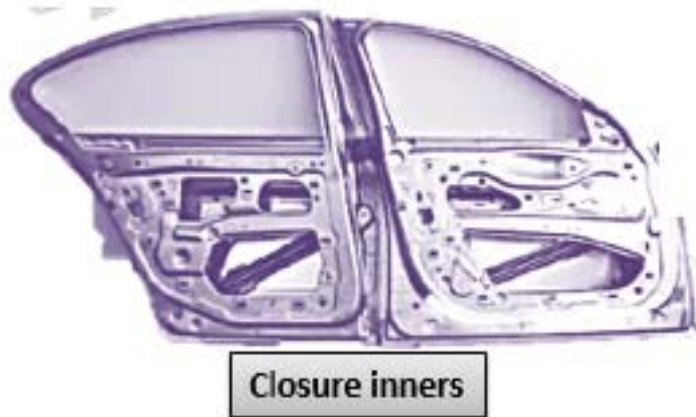

ALUMINUM EXTRUSION CONTENT – BUMPERS, STRUCTURES

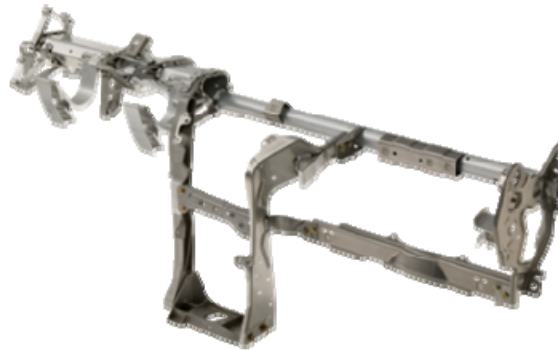

ALUMINUM BODY-IN-WHITE CONTENT – SHEET, EXTRUSIONS, CASTINGS

- Aluminum by 2025:
 - BIW: 12-18%

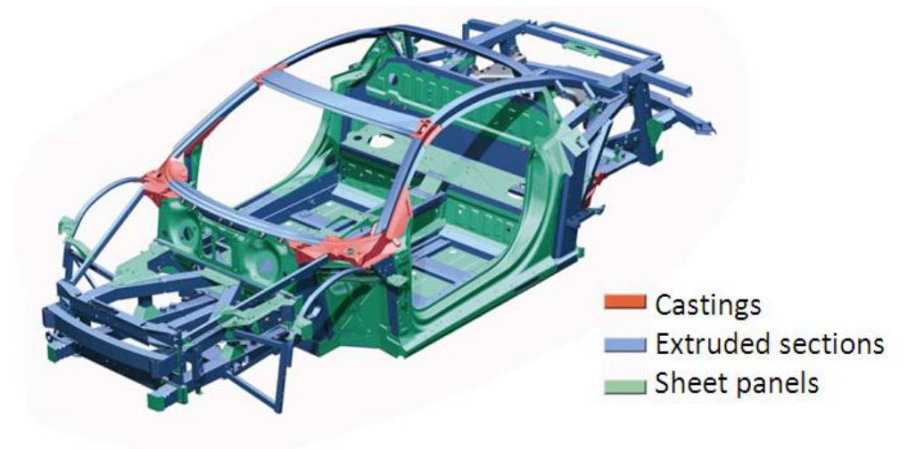

SIGNIFICANT **GROWTH OPPORTUNITY:** AUTOMOTIVE ALUMINUM FABRICATION

Aluminum Value Stream Opportunities:

■ Sheet and Extrusion Components

■ Service Center

- Warehousing, slitting, blanking, CTL

■ Fabrication – Extrusions

- Cut, mill, drill...
- Bend
- Joining (welding, rivet-bonding)
- Hydroform

■ Fabrication – Sheet

- Slit, blank, tailor welded blank
- Stamp, punch, trim
- Thermal Aging
- Coating
- Recycling (important emerging priority)

THANK YOU!



Novelis

KAISER
ALUMINUM



Aleris

 Constellium

RioTinto
Alcan



sapa:

QUESTIONS?